

EpoxyPlus EX

Seismically-qualified, high-performance pure epoxy resin for bonding steel bars in concrete, solid masonry, hard natural stone and solid rock

APPLICATIONS

- Structural steel to cracked and non-cracked concrete
- Threaded bars and reinforcing bars
- Rebar and starter bars
- Safety barriers, fences, racking, brackets
- Suitable for applications prone to dynamic loads and vibrations and in external environments

FEATURES AND BENEFITS

- Seismically-qualified
- Fixings close to free edges
- Anchoring without expansion pressure
- High load capacities
- Fire resistant with the use of reinforcing bars up to F240 classification



EpoxyPlus EX has been tested in accordance with US standard AC308 for recognition under the IBC / IRC codes to resist seismic actions in Seismic Design Categories A – F.

EPOXYPLUS EX

Packaging	600ml side-by-side cartridge
Shelf life	600ml side-by-side cartridge
Storage conditions	Store in cool conditions (5 – 25°C) out of direct sunlight
Colour	Grey
Mixing ratio	1:1 by volume Component A : Component B



For full product information, case studies and downloadable repair details go to:
www.helifix.co.uk/products/remedial-products/EpoxyPlus/

WORKING AND LOAD TIMES

Resin Cartridge Temp.	T Work	Base Material Temp.	T Load
10 to 15°C	20 minutes	5 to 10°C	24 hours
10 to 15°C	20 minutes	10 to 15°C	12 hours
15 to 20°C	15 minutes	15 to 20°C	8 hours
20 to 25°C	11 minutes	20 to 25°C	7 hours
25 to 30°C	8 minutes	25 to 30°C	6 hours
30 to 35°C	6 minutes	30 to 35°C	5 hours
35 to 40°C	4 minutes	35 to 40°C	4 hours
40°C	3 minutes	40°C	3 hours

NOTE: T Work is the typical time to gel at the highest temperature in the range.
T Load is the typical time to reach maximum load.

PHYSICAL PROPERTIES

Property	Unit	Value	Test Standard
4 hours	N/mm ²	-	ASTM D 1875 @ 20°C
Compressive Strength	24 hours	N/mm ²	ASTM D 695 @ 20°C
	7 days	N/mm ²	ASTM D 695 @ 20°C
Tensile Strength	24 hours	N/mm ²	ASTM D 638 @ 20°C
	7 days	N/mm ²	ASTM D 638 @ 20°C
Elongation at Break	24 hours	%	ASTM D 638 @ 20°C
	7 days	%	ASTM D 638 @ 20°C
Tensile Modulus	24 hours	psi	ASTM D 638 @ 20°C
	7 days	psi	ASTM D 638 @ 20°C
Flexural Strength	24 hours	N/mm ²	ASTM D 790 @ 20°C
HDT	7 days	°C	ASTM D 648 @ 20°C

ASTM C 881 TESTING

According to ASTM C 881-2010 Test Method	Class C (For use above 15°C)
Consistency (ASTM C 881)	0.014 in.
Gel Time (ASTM C 881)	10 minutes
Bond Strength, 2 day cure (ASTM C 882)	2656 psi
Compressive Yield Strength (ASTM D 695)	13 810 psi
Compressive Modulus (ASTM D 695)	421 293 psi
Water Absorption (ASTM D 570)	0.08%
Heat Deflection Temperature (ASTM D 468)	46°C
Linear Coefficient of Shrinkage (ASTM D 2566)	0.0003 in/in

CHEMICAL RESISTANCE

EpoxyPlus EX chemical anchoring mortar has undergone extensive chemical resistance testing. The results are summarised in the table below.

Chemical Environment	Class C (For use above 15°C)	Result
Aqueous Solution Acetic Acid	10%	C
Acetone	100%	✗
Aqueous Solution Aluminium Chloride	Saturated	✓
Aqueous Solution Aluminium Nitrate	10%	✓
Ammonia Solution	5%	✓
Jet Fuel	100%	C
Benzene	100%	C
Benzoic Acid	Saturated	✓
Benzyl Alcohol	100%	✗
Sodium Hypochlorite Solution	5-15%	✓
Butyl Alcohol	100%	C
Calcium Sulphate Aqueous Solution	Saturated	✓
Carbon Monoxide	Gas	✓
Carbon Tetrachloride	100%	C
Chlorine Water	Saturated	✗
Chloro Benzene	100%	✗
Citric Acid Aqueous Solution	Saturated	✓
Cyclohexanol	100%	✓
Diesel Fuel	100%	C
Diethylene Glycol	100%	✓
Ethanol	95%	✗
Ethanol Aqueous Solution	20%	C
Heptane	100%	C
Hexane	100%	C
Hydrochloric Acid	10%	✓
	15%	✓
	25%	C
Hydrogen Sulphide Gas	100%	✓
Isopropyl Alcohol	100%	✗
Linseed Oil	100%	✓
Lubricating Oil	100%	✓
Mineral Oil	100%	✓
Paraffin / Kerosene (Domestic)	100%	C
Phenol Aqueous Solution	1%	C
Phosphoric Acid	50%	✓
Potassium Hydroxide	10% / pH13	✓
Sea Water	100%	C
Styrene	100%	C

Sulphur Dioxide Solution	10%	✓
Sulphur Dioxide	(40°C) 5%	✓
Sulphuric Acid	10%	✓
	50%	✓
Turpentine	100%	C
White Spirit	100%	✓
Xylene	100%	C

Key:

✓ = Resistant to 75°C with at least 80% of physical properties retained.

C = Contact only to a maximum of 26°C.

✗ = Not Resistant.

INSTALLATION INSTRUCTIONS

Solid Substrate Installation Method

- Using the SDS Hammer Drill with a carbide tipped drill bit of the appropriate size, drill the hole to suit the anchor.
- a) Select the correct Air Lance, insert to the bottom of the hole and depress the trigger for 2 seconds. The compressed air must be clean – free from water and oil – and at a minimum pressure of 90psi (6bar).

Blow Clean x 2. b) If a Manual Pump is to be used, complete the blowing operation as above using the full stroke of the pump and **Blow Clean x 2**.

NOTE: A Manual Pump may only be used on sizes M10-M16 and to a maximum depth <200mm.

- Select the correct size Hole Cleaning Brush. Ensure that the brush is in good condition and the correct diameter. Insert the brush to the bottom of the hole and withdraw with a twisting motion. There should be positive interaction between the steel bristles of the brush and the sides of the drilled hole.

Brush Clean x 2.

- Repeat 2 (a) or (b)
- Repeat 3
- Repeat 2 (a) or (b)
- Select the appropriate static mixer nozzle and attach to the cartridge. Check the Applicator is in good working order. Insert the cartridge into the dispensing tool.

NOTE: The QH nozzle is in two sections. One section contains the mixing elements and the other section is an extension piece. Connect the extension piece to the mixing section by pushing the two sections firmly together until a positive engagement is felt.

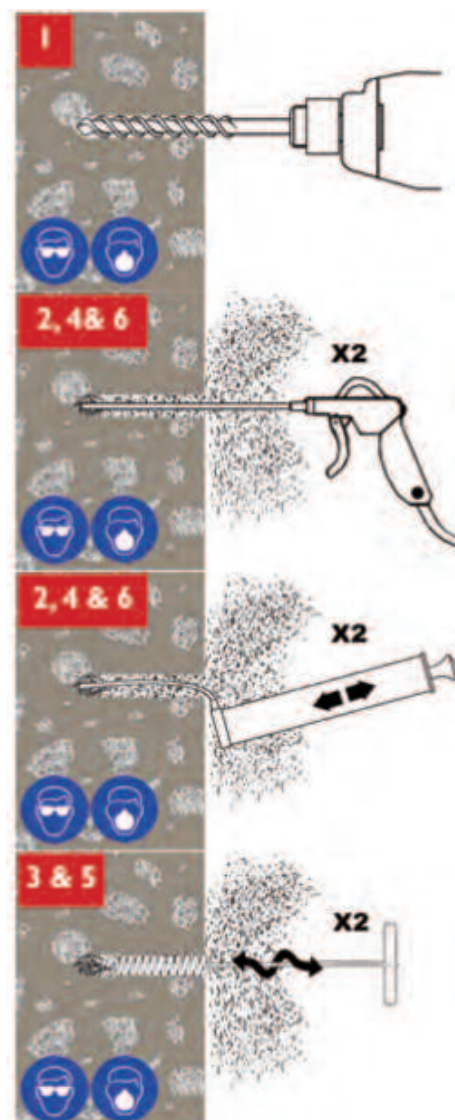

- 7.
8. Extrude some resin to waste until an even - colored mixture is extruded.
The cartridge is now ready for use.
9. As specified in the Installation Accessories Table, attach an extension tube with resin stopper (if required) to the end of the mixing nozzle with a push fit. (The extension tubes may be pushed into the resin stoppers and are held in place with a coarse internal thread).
10. Insert the mixing nozzle to the bottom of the hole. Extrude the resin and slowly withdraw the nozzle from the hole. **Ensure no air voids are created** as the nozzle is withdrawn. Inject resin until the hole is approximately 3/4 full and remove the nozzle from the hole.
11. Select the steel anchor element ensuring it is free from oil or other contaminants. Insert the steel element into the hole using a back-and-forth twisting motion to ensure complete cover, until it reaches the bottom of the hole. Excess resin will be expelled from the hole evenly around the steel element.
12. Clean any excess resin from around the mouth of the hole.
13. **Do not disturb** the anchor until at least the minimum cure time has elapsed. Refer to the Working & Loading Times table on page 2.
14. Position the fixture and tighten the anchor to the appropriate installation torque.

Do not over-torque the anchor as this could adversely affect its performance.



OVERHEAD SUBSTRATE INSTALLATION METHOD

- Using the SDS Hammer Drill with a carbide tipped drill bit of the appropriate size, drill the hole to suit the anchor.
- a) Select the correct Air Lance, insert to the bottom of the hole and depress the trigger for 2 seconds. The compressed air must be clean – free from water and oil – and at a minimum pressure of 90psi (6bar).

Blow Clean x2.

b) If a Manual Pump is to be used, complete the blowing operation as above using the full stroke of the pump and Blow Clean x2.

NOTE: A Manual Pump may only be used on sizes M10-M16 and to a maximum depth <200mm.

- Select the correct size Hole Cleaning Brush. Ensure that the brush is in good condition and the correct diameter. Insert the brush to the bottom of the hole and withdraw with a twisting motion. There should be positive interaction between the steel bristles of the brush and the sides of the drilled hole.

Brush Clean x 2.

- Repeat 2 (a) or (b)
- Repeat 3
- Repeat 2 (a) or (b)
- Select the appropriate static mixer nozzle and attach to the cartridge. Check the Applicator is in good working order. Insert the cartridge into the dispensing tool.

NOTE: The QH nozzle is in two sections. One section contains the mixing elements and the other section is an extension piece. Connect the extension piece to the mixing section by pushing the two sections firmly together until a positive engagement is felt.

- Extrude some resin to waste until an even-colored mixture is extruded, The cartridge is now ready for use.
- As specified in the Installation Accessories Table, attach an extension tube with resin stopper (if required) to the end of the mixing nozzle with a push fit. (The extension tubes may be pushed into the resin stoppers and are held in place with a coarse internal thread).
- Insert the mixing nozzle to the bottom of the hole. Extrude the resin and slowly withdraw the nozzle from the hole. Ensure no air voids are created as the nozzle is withdrawn. Inject resin until the hole is approximately 3/4 full and remove the nozzle from the hole.

- Select the steel anchor element ensuring it is free from oil or other contaminants. Insert the steel element into the hole using a back- and-forth twisting motion to ensure complete cover, until it reaches the bottom of the hole. Excess resin will be expelled from the hole evenly around the steel element.
- Clean any excess resin from around the mouth of the hole.
- Do not disturb** the anchor until at least the minimum cure time has elapsed. Refer to the Working & Loading Times table on page 2.
- Position the fixture and tighten the anchor to the appropriate installation torque.

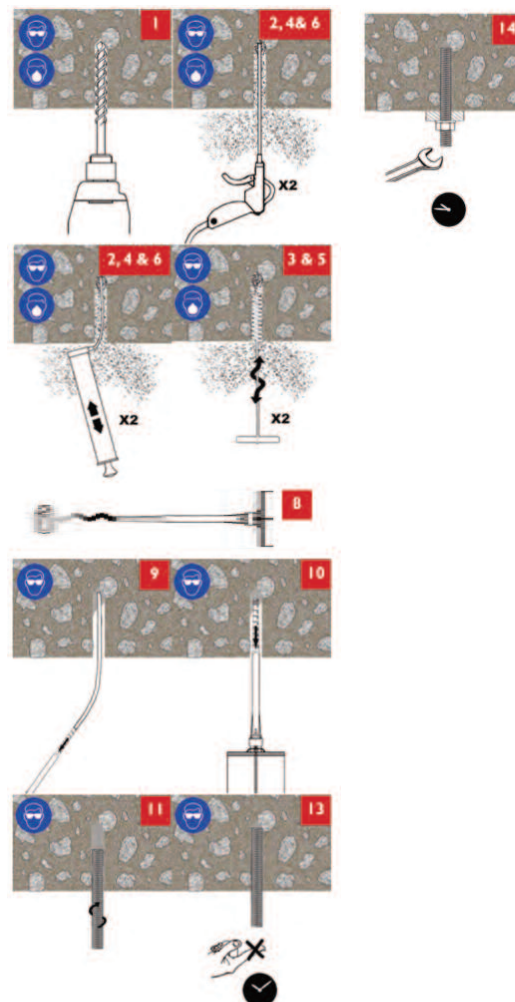

Do not over-torque the anchor as this could adversely affect its performance.

NOTE: The use of wedges to secure the anchor during loading time is not required.

INSTALLATION ACCESSORIES – THREADED BAR

Anchor Size	Drilled Hole Diameter	Brush Size	Nozzle Type	Extension Tube Required	Resin Stopper Required	Notes
M10	12	S14H	Q	Y1 > 90mm h_{ef}	N	
M12	14	S16H	Q	Y1 > 90mm h_{ef}	N	
M16	18	S22H	Q QH	Y2 > 250mm h_{ef}	RS18 > 250mm h_{ef}	QH nozzle required at h_{ef} > 200mm
M20	22	S24H	QH	Y2 > 250mm h_{ef}	RS18 > 250mm h_{ef}	
M22	25	S27H S27F	QH QH	Y2 > 250mm h_{ef}	RS22 > 200mm h_{ef}	SF27F brush required at h_{ef} > 380mm
M24	26	S31H S31F	QH QH	Y2 > 250mm h_{ef}	RS22 > 200mm h_{ef}	SF31F brush required at h_{ef} > 380mm
M30	35	S38H S38F	QH QH	Y2 > 250mm h_{ef}	RS30 > 200mm h_{ef}	SF38F brush required at h_{ef} > 380mm

INSTALLATION ACCESSORIES - REINFORCING BAR

Anchor Size	Drilled Hole Diameter	Brush Size	Nozzle Type	Extension Tube Required	Resin Stopper Required	Notes
T10	14	S16H	Q	Y1 > 90mm h_{ef}	N	
T12	16	S18H	QH Q	Y1 > 90mm h_{ef}	N	QH nozzle required at h_{ef} > 90mm
T16	20	S22H	QH Q	Y2 > 250mm h_{ef}	RS18 > 250mm h_{ef}	QH nozzle required at h_{ef} > 200mm
T20	25	S27H S27F	QH	Y2 > 250mm h_{ef}	RS18 > 250mm h_{ef}	
T25	32	S35H S35F	QH	Y2 > 250mm h_{ef}	RS22 > 200mm h_{ef}	SF31F nozzle required at h_{ef} > 380mm
T32	40	S43H S43F	QH	Y2 > 250mm h_{ef}	RS30 > 200mm h_{ef}	SF38F nozzle required at h_{ef} > 380mm

Key

Extension Tubes

Y1	Required: 38 diameter fitted to Q
Y2	Required: 916 diameter fitted to QH
N	Not required

Resin Stoppers

N	Not required
RS16	Use 18mm dia resin stopper
RS22	Use 22mm dia resin stopper
RS30	Use 30mm dia resin stopper

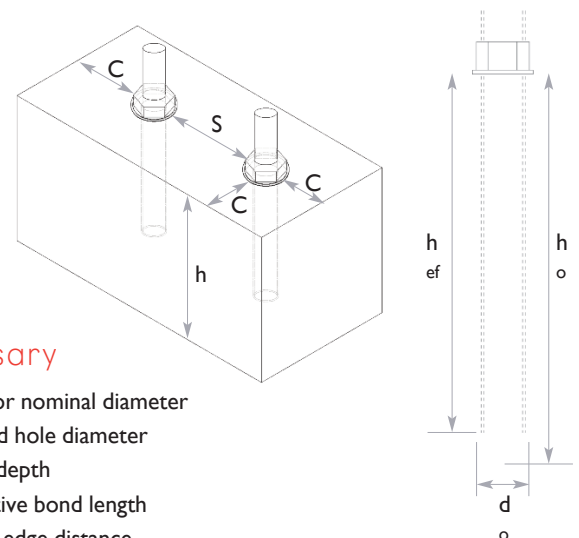

Glossary

- d anchor nominal diameter
- d_o drilled hole diameter
- h_o hole depth
- h_{ef} effective bond length
- C close edge distance
- S anchor spacing
- h concrete member thickness

USING EX WITH THREADED BARS

Steel Design Information for Threaded Rod - General

Characteristic	Symbol	Nominal Rod Diameter, d_o						
		M10	M12	M16	M18	M20	M24	M30
Nominal Size	d_o	58	84	157	192	245	353	561
Stress Area	A_{se}	58	84	157	192	245	353	561
Effectiveness Factor for Uncracked Concrete, Breakout	k_{uncr}	10.0						
Effectiveness Factor for Cracked Concrete, Breakout	k_{cr}	7.1						
k_{uncr} / k_{cr}	$Y_{cr,N}$	1.41						
Strength Reduction Factor for Concrete Breakout Failure in Tension	f	0.65						
Strength Reduction Factor for Tension, Steel Failure	f	0.75						
Strength Reduction Factor for Concrete Breakout Failure in Shear	f	0.70						
Strength Reduction Factor for Concrete Pryout Failure in Shear	f	0.70						
Strength Reduction Factor for Shear, Steel Failure	f	0.65						
Additional Factor for Seismic Tension	$\alpha_{N,seis}$	1.00						
Reduction for Seismic Shear, Carbon Steel, ASTM F 1554 Grade 36 (A 307 C)	$\alpha_{V,seis}$	1.00						
Reduction for Seismic Shear, Carbon Steel, ASTM A 193 B7	$\alpha_{V,seis}$	1.00						
Reduction for Seismic Shear, Stainless Steel, ASTM F 593	$\alpha_{V,seis}$	1.00						
Reduction for Seismic Shear, Carbon Steel, ASTM A615, Reinforcement Bar	$\alpha_{V,seis}$	1.00						
Reduction for Seismic Shear, Carbon Steel, ISO 898-1	$\alpha_{V,seis}$	1.00						
Reduction for Seismic Shear, Stainless Steel, ISO 3506-1	$\alpha_{V,seis}$	1.00						
Reduction for Seismic Shear, Carbon Steel, DIN 488 Reinforcement Bar	$\alpha_{V,seis}$	1.00						
Reduction for Seismic Shear, Carbon Steel, CAN/CSA-G30.18 Gr. 400, Reinforcement Bar	$\alpha_{V,seis}$	1.00						

Steel Design Information for Threaded Rod - SI

Characteristic	Symbol	Units	Nominal Rod Diameter, d_o						
			M10	M12	M16	M18	M20	M24	M30
Nominal Size	d_o	mm	58	84	157	192	245	353	561
Stress Area ¹	A_{se}	mm ²	58	84	157	192	245	353	561
Tension Resistance of Carbon Steel ISO 898-1 Class 5.8	N_{sa}	kN	29.0	42.2	78.5	96.0	122.5	176.5	280.5
Tension Resistance of Carbon Steel ISO 898-1 Class 8.8	N_{sa}	kN	46.4	67.4	125.6	153.6	196.0	282.4	448.8
Tension Resistance of Carbon Steel ISO 898-1 Class 12.9	N_{sa}	kN	50.0	72.7	135.3	165.5	211.2	304.3	483.6
Tension Resistance of Stainless Steel ISO 3506-1 A4-70	N_{sa}	kN	40.6	59.0	109.9	134.4	171.5	247.1	392.7
Tension Resistance of Stainless Steel ISO 3506-1 A4-80	N_{sa}	kN	46.4	67.4	125.6	153.6	196.0	282.4	448.8

Steel Design Information for Threaded Rod - SI (Continued...)

Characteristic	Symbol	Units	Nominal Rod Diameter, d_o						
			Nominal Size	M10	M12	M16	M18	M20	M24
Stress Area ¹	Ase	mm ²	58	84	157	192	245	353	561
Shear Resistance of Carbon Steel ISO 898-1 Class 5.8	V_{sa}	kN	17.4	25.3	47.1	57.6	73.5	105.9	168.3
Shear Resistance of Carbon Steel ISO 898-1 Class 8.8	V_{sa}	kN	27.8	40.5	75.4	92.2	117.6	169.4	269.3
Shear Resistance of Carbon Steel ISO 898-1 Class 12.9	V_{sa}	kN	30.0	43.6	81.2	99.3	127.6	182.6	290.1
Shear Resistance of Stainless Steel ISO 3506-1 A4-70	V_{sa}	kN	24.4	35.4	65.9	80.6	102.9	148.3	235.6
Shear Resistance of Stainless Steel ISO 3506-1 A4-80	V_{sa}	kN	27.8	40.5	75.4	92.2	117.6	169.4	269.3

¹Stress Area is minimum area for either tension or shear.

Bond Strength Design Information - Threaded Rod

Design Information		Units	Nominal Threaded Rod Diameter							
			M10	M12	M16	M20	M22	M24	M30	
Minimum Effective Installation Depth		$h_{ef,min}$	mm	60	70	79	89	102	102	127
Maximum Effective Installation Depth		$h_{ef,max}$	mm	191	254	318	381	445	508	635
Temperature Range A ¹	Characteristic Bond Strength in Uncracked Concrete	$T_{k,uncr}$	N/mm ²	11.92						
	Characteristic Bond Strength in Cracked Concrete	$?k_{cr}$	N/mm ²	10.06	9.72	9.03	8.67	8.33	7.64	6.60
Temperature Range B ²	Characteristic Bond Strength in Uncracked Concrete	$?k_{uncr}$	N/mm ²	5.15						
	Characteristic Bond Strength in Cracked Concrete	$?k_{cr}$	N/mm ²	4.34	4.20	3.90	3.75	3.60	3.30	2.85
Temperature Range C ³	Characteristic Bond Strength in Uncracked Concrete	$?k_{uncr}$	N/mm ²	4.08						
	Characteristic Bond Strength in Cracked Concrete	$?k_{cr}$	N/mm ²	3.45	3.33	3.09	2.97	2.85	2.62	2.26

Symbols unavailable in current font

Bond Strength Design Information - Threaded Rod (Continued...)

Design Information		Units		Nominal Threaded Rod Diameter						
				M10	M12	M16	M20	M22	M24	M30
Permissible Installation Conditions ^{4,5}	Dry Concrete	φ_d	Periodic inspection	0.65						
		K_d		1.00						
	Water-Saturated Concrete	φ_{ws}		0.45						
		K_{ws}		0.84	1.00					
	Water-filled Hole	φ_{wf}		0.45						
		K_{wf}		0.95	1.00				0.46	
	Dry Concrete	φ_d	Continuous inspection	0.65						
		K_d		1.00						
	Water-Saturated Concrete	φ_{ws}		0.45	0.55					
		K_{ws}		1.00						
	Water-filled Hole	φ_{wf}		0.45	0.55				0.45	
		K_{wf}		1.00						0.54

¹ Temperature Range A = 20C (Max Long Term); 43C (Max Short Term)

² Temperature Range B = 43C (Max Long Term); 72C (Max Short Term)

³ Temperature Range C = 43C (Max Long Term); 80C (Max Short Term)

⁴ factors corresponding to Condition B according to ACI 318 - 11 for post-installed anchors

⁵ Additional Factor for installation condition

Symbols unavailable in current font

Flow chart to establish design bond strength

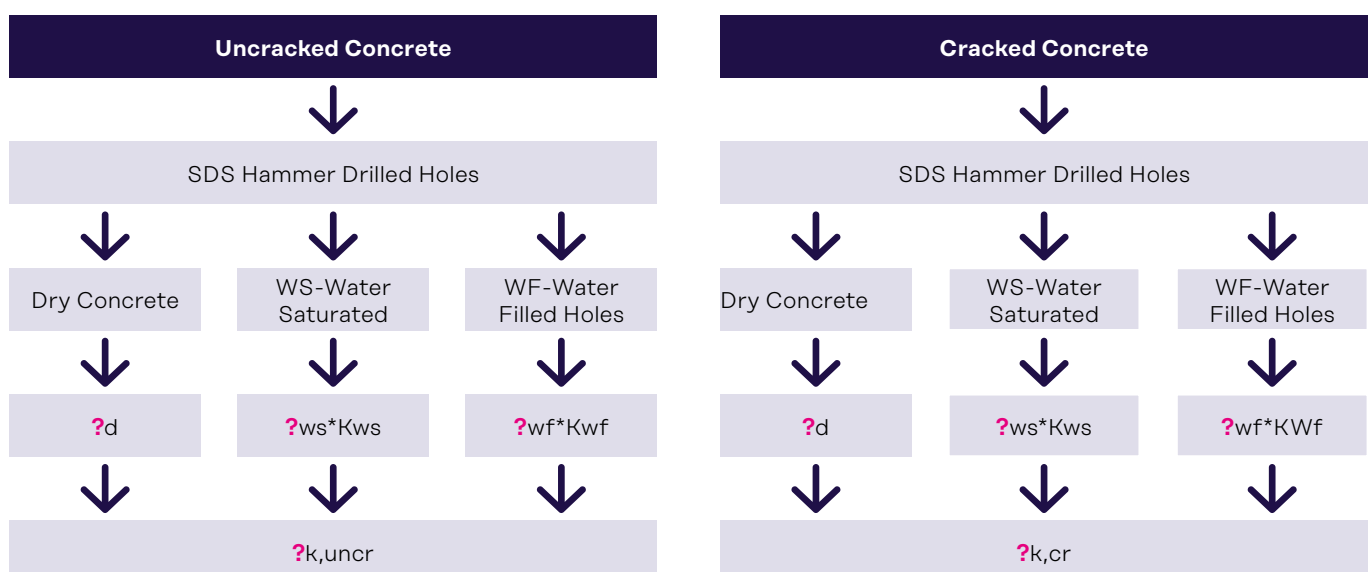

Using EX with Reinforcing Bar

STEEL DESIGN INFORMATION FOR REINFORCING BAR - GENERAL

Characteristic	Symbol	Units	Reinforcement Bar Reference					
			Nominal Size	T10	T12	T16	T20	T25
Stress Area	Ase	mm ²	78.5	113	201	314	491	804
Effectiveness Factor for Uncracked Concrete, Breakout	k_{uncr}					10.0		
Effectiveness Factor for Cracked Concrete, Breakout	k_{cr}					7.1		
k_{uncr} / k_{cr}	$\gamma_{cr,N}$					1.41		
Strength Reduction Factor for Concrete Breakout Failure in Tension	f					0.65		
Strength Reduction Factor for Tension, Steel Failure	f					0.75		
Strength Reduction Factor for Concrete Breakout Failure in Shear	f					0.70		
Strength Reduction Factor for Concrete Pryout Failure in Shear	f					0.70		
Strength Reduction Factor for Shear, Steel Failure	f					0.65		
Additional Factor for Seismic Tension	$\gamma_{v,seis}$					1.00		
Reduction for Seismic Shear, Carbon Steel, ASTM F 1554 Grade 36 (A 307 C)	$\gamma_{v,seis}$					1.00		
Reduction for Seismic Shear, Carbon Steel, ASTM A 193 B7	$\gamma_{v,seis}$					1.00		
Reduction for Seismic Shear, Stainless Steel, ASTM F 593	$\gamma_{v,seis}$					1.00		
Reduction for Seismic Shear, Carbon Steel, ASTM A615, Reinforcement Bar	$\gamma_{v,seis}$					1.00		
Reduction for Seismic Shear, Carbon Steel, ISO 898-1	$\gamma_{v,seis}$					1.00		
Reduction for Seismic Shear, Stainless Steel, ISO 3506-1	$\gamma_{v,seis}$					1.00		
Reduction for Seismic Shear, Carbon Steel, DIN 488 Reinforcement Bar	$\gamma_{v,seis}$					1.00		
Reduction for Seismic Shear, Carbon Steel, CAN/ CSA-G30.18 Gr. 400, Reinforcement Bar	$\gamma_{v,seis}$					1.00		

**STEEL DESIGN INFORMATION FOR
REINFORCING BAR - SI**

Characteristic	Symbol	Units	Nominal Rod Diameter, d_o					
			Nominal Size	d_o	mm	T10	T12	T16
Stress Area ¹	Ase	mm ²	78.5	113	201	314	491	804
Tension Resistance of Reinforcing Bar DIN 488 BSt 500	Nsa	kN	43.2	62.2	110.6	172.7	270.1	442.2
Tension Resistance of Reinforcing Bar CAN/ CSA-G30.18 Gr. 400	Nsa	kN	42.4	61.0	108.5	169.6	265.1	434.2
Shear Resistance of Reinforcing Bar DIN 488 BSt 500	Vsa	kN	25.9	37.3	66.3	103.6	162.0	265.3
Shear Resistance of Reinforcing Bar CAN/ CSA-G30.18 Gr. 400	Vsa	kN	25.9	36.3	65.1	101.7	159.1	260.5

¹ Stress Area is minimum area for either tension or shear.

**BOND STRENGTH DESIGN INFORMATION
- REINFORCING BAR**

Design Information		Units	Nominal Threaded Rod Diameter							
			T10	T12	T16	T18	T20	T25	T32	
Minimum Effective Installation Depth		$h_{ef,min}$	mm	60	70	79	89	102	102	127
Maximum Effective Installation Depth		$h_{ef,max}$	mm	191	254	318	381	445	508	635
Temperature Range A ¹	Characteristic Bond Strength in Uncracked Concrete	?k,uncr	N/mm ²	11.92						
	Characteristic Bond Strength in Cracked Concrete	?k,cr	N/mm ²	10.06	9.72	9.03	8.67	8.33	7.47	6.25
Temperature Range B ²	Characteristic Bond Strength in Uncracked Concrete	?k,uncr	N/mm ²	5.15						
	Characteristic Bond Strength in Cracked Concrete	?k,cr	N/mm ²	4.34	4.20	3.90	3.75	3.60	3.23	2.70
Temperature Range C ³	Characteristic Bond Strength in Uncracked Concrete	?k,uncr	N/mm ²	4.08						
	Characteristic Bond Strength in Cracked Concrete	?k,cr	N/mm ²	3.45	3.33	3.09	2.97	2.85	2.56	2.14

**BOND ST RENGTH DESIGN INFORMATION
- REINFORCING BAR (CONTINUED...)**

Design Information		Units		Nominal Threaded Rod Diameter						
				T10	T12	T16	T18	T20	T25	T32
Permissible Installation Conditions ^{4,5}	Dry Concrete	?d	Periodic inspection	0.65						
		Kd		1.00						
	Water Saturatred Concrete	?ws		0.45						
		Kws		0.84	1.00					
	Water Filled Hole	?wf		0.45						
		Kwf		0.95	1.00				0.46	
	Dry Concrete	?d	Continuous inspection	0.65						
		Kd		1.00						
	Water-Saturated Concrete	?ws		0.45	0.55					
		Kws		1.00						
	Water-filled Hole	?wf		0.45	0.55				0.45	
		Kwf		1.00					0.54	

1. Temperature Range A = 20C (Max Long Term); 43C (Max Short Term)
2. Temperature Range B = 43C (Max Long Term); 72C (Max Short Term)
3. Temperature Range C = 43C (Max Long Term); 80C (Max Short Term)
4. ? factors corresponding to Condition B according to ACI 318 - 11 for post-installed anchors
5. Additional Factor for installation condition

FLOW CHART TO ESTABLISH DESIGN BOND STRENGTH

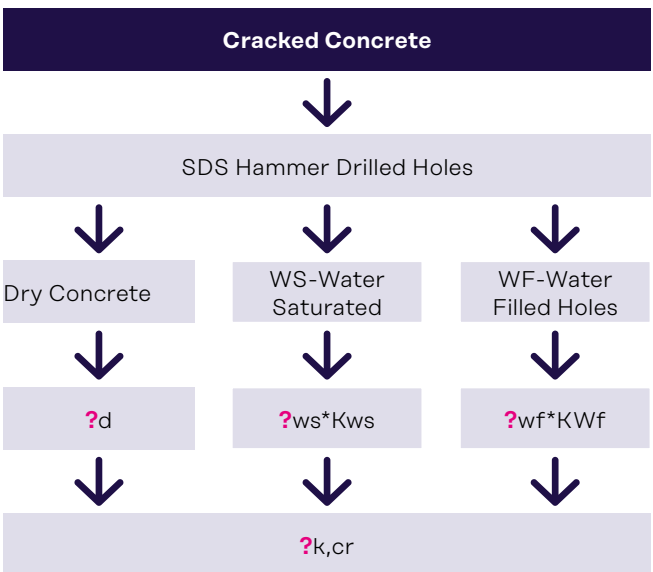
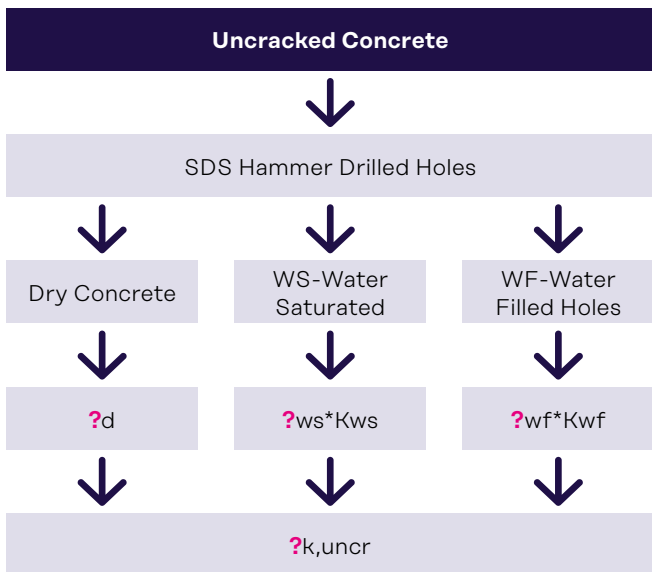

Healthy and Safety

EpoxyPlus EX consists of epoxy resins and hardener systems, which are currently classified as hazardous materials.

Wear suitable protective clothing, eye/face protection and gloves, and ensure adequate ventilation.

An EpoxyPlus EX Safety Data Sheet is available to download at www.helifix.co.uk